

Power Amplifiers for CVU**-EFP1 Electrohydraulic Proportional Throttle Valves

EEA-PAM-571-A-14 Design

General Description

This basic amplifier is designed for driving Vickers type CVU**-EFP1 proportional throttle valves in applications requiring only one (adjustable) ramp setting for both acceleration and deceleration.

Analog command input signals can be non-inverting current, or non-inverting, inverting or differential voltages. The amplifier requires a power supply of 24V DC and is enabled by a 24V logic signal. The ramp is normally enabled

but can be selectively disabled by suitable wiring to an external switch.

The amplifier front panel contains LEDs showing the status of power, control supply and outputs. Potentiometers for adjusting ramp, deadband compensation and gain are also mounted on the front panel.

Features

- Basic valve amplifier.
- Voltage and current command signals.

- 1 ramp for acceleration and deceleration.
- 24V DC power supply.
- Pulse-width-modulated coil drives.
- Wider supply voltage range plus high tolerance to ripple.
- Low supply voltage protection.
- Additional monitor points on edge connector.
- Gain positioned in circuitry to give:
 - Ramp setting unaffected by gain adjustment
 - Constant trigger voltage for deadband compensation.

Panel Display

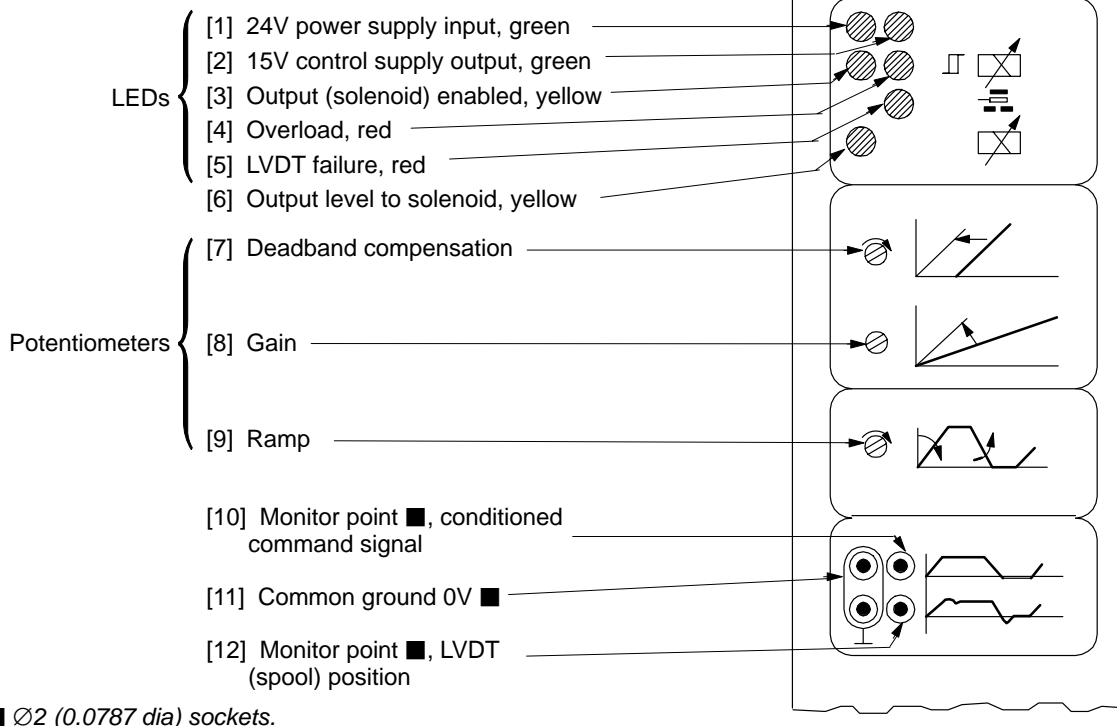

Warning: Electromagnetic Compatibility (EMC)

This product does not conform to the European Community directives for electromagnetic compatibility (EMC). It is only suitable for use within the European Economic Area in a sealed electromagnetic environment or as a spare for an existing machine. (Ref. UK Electromagnetic Compatibility Regulations 14 & 18, 1995.)

Operating Data

Power (input) supply		20 to 34V DC x 40W max. 24V DC nominal <4V pk-to-pk ripple amplifier shuts down below 19V
Control (output) supplies	z22 z2 b2	+15V x 50 mA max. in addition to LVDT demand +10V x 5 mA max. -10V x 5 mA max.
Command signal inputs:		
Direct voltage pins	b8, b6, z8, b10	
Inverting voltage pin	z10	
Voltage range		0 to 10V
Input impedance (voltage)		47 k Ω
Current pin	z6	
Current range		0 to 20 mA
Input impedance (current)		100 Ω
Standing solenoid current at zero command signal		1.1A
Deadband compensation:		
Factory setting		10% of max. stroke▲
Adjustment		0 to 50% of max. stroke▲
Gain control:		
Factory setting		Max. spool stroke at 10V command signal▲
Adjustment per direction from centered position		1.9 to 20% of max. spool stroke per V▲
Ramp time adjustment, linear:		
Factory setting		Max. time
Adjustment		50 ms to 2s, under pre-set deadband compensation and gain conditions
Dither		Factory-set
Feedback from LVDT	b14	12 to 20 mA (100 Ω)
Overload protection, factory-set		Automatic reset when fault removed
Output enabled (power available to solenoid)	z24	Apply 10 to 30V (6,8 k Ω)
Output disabled (no power output to solenoid)	z24	Apply \leq 0,8V or open circuit
Ramp enabled (machine actuator acceleration and deceleration limited by ramp potentiometer)	b12/b20	Open circuit between b20 and b12
Ramp disabled (fastest acceleration and deceleration of machine actuator; ramp circuit bypassed)	b12/b20	Link b20 to b12
Command signal monitor point		5V full scale. Command signal conditioned by deadband compensation, gain and ramp functions
Spool position monitor point	Front panel and z18	5V full scale
Monitor point impedance	Front panel and b18	10 k Ω
Monitor point protection		Short-circuit protected
Output point to alarm indicator	z12	>+6V when enabled <-6V when disabled
Ambient temperature range		0 to 50°C (32 to 122°F)
Mass		0,22 kg (0.48 lb)

▲ From spool-closed position.

Circuit and Connections

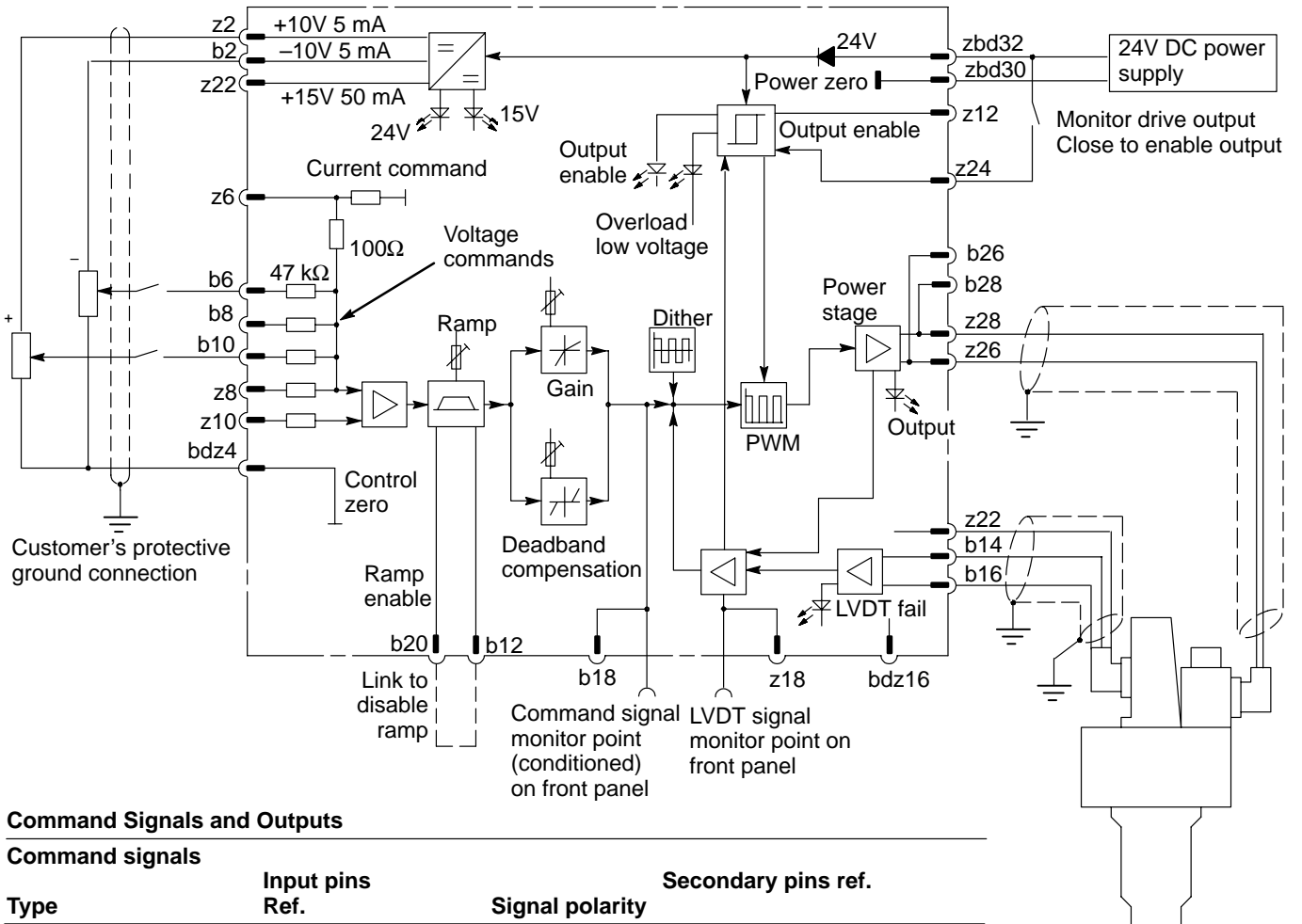

Command Signals and Outputs

Command signals

Type	Input pins Ref.	Signal polarity	Secondary pins ref.
Non-inverting voltages	b6/8/10 or z8	+	bdz4
Non-inverting current	z6	+	bdz4
Inverting voltage	z10	-	Link one of b6/8/10 or z8 to bdz4
Differential voltage	z10	-	One of b6/8/10 or z8
	One of b6/8/10 or z8	+	z10

Valve Wiring Connections

Solenoid Connections

Note: Connections *not* polarity sensitive

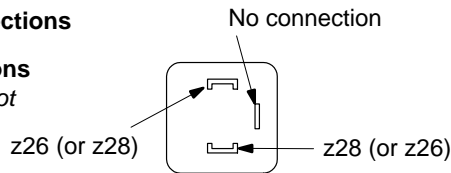

LVDT Connections

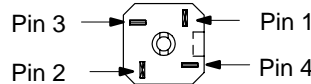

LVDT plug pin	Amplifier pin
1	b14
2	z22
3	bdz16
4	-

Amplifier Cardholder, part number 02-104807

Vickers amplifiers (plug-in units of 3U height to IEC 297) clip into this type of cardholder, which prevents them from accidentally working loose. Cardholders have a female edge connector to DIN 41612, F32 for the amplifier connection

and screw terminals for wiring connections

Female Edge Connector for 19" Rack Mounting, part number 508178

This female edge connector, DIN 41612 type F48, has terminals to which the wires can be soldered. The connectors can be

user-fitted into 19" rack housing designed to accept a number of amplifiers.

Supporting products:

Power supply unit options	EHH PSU 704 * 20
Portable test equipment	EHA TEQ 700 A 20

Installation Dimensions in mm (inches)

Plug-in Unit of 3U Height, to IEC 297

