

Vickers®

Filters

Service Data

High Performance/Pressure Filter Flows to 76 L/min (20 USgpm) HT15 Series

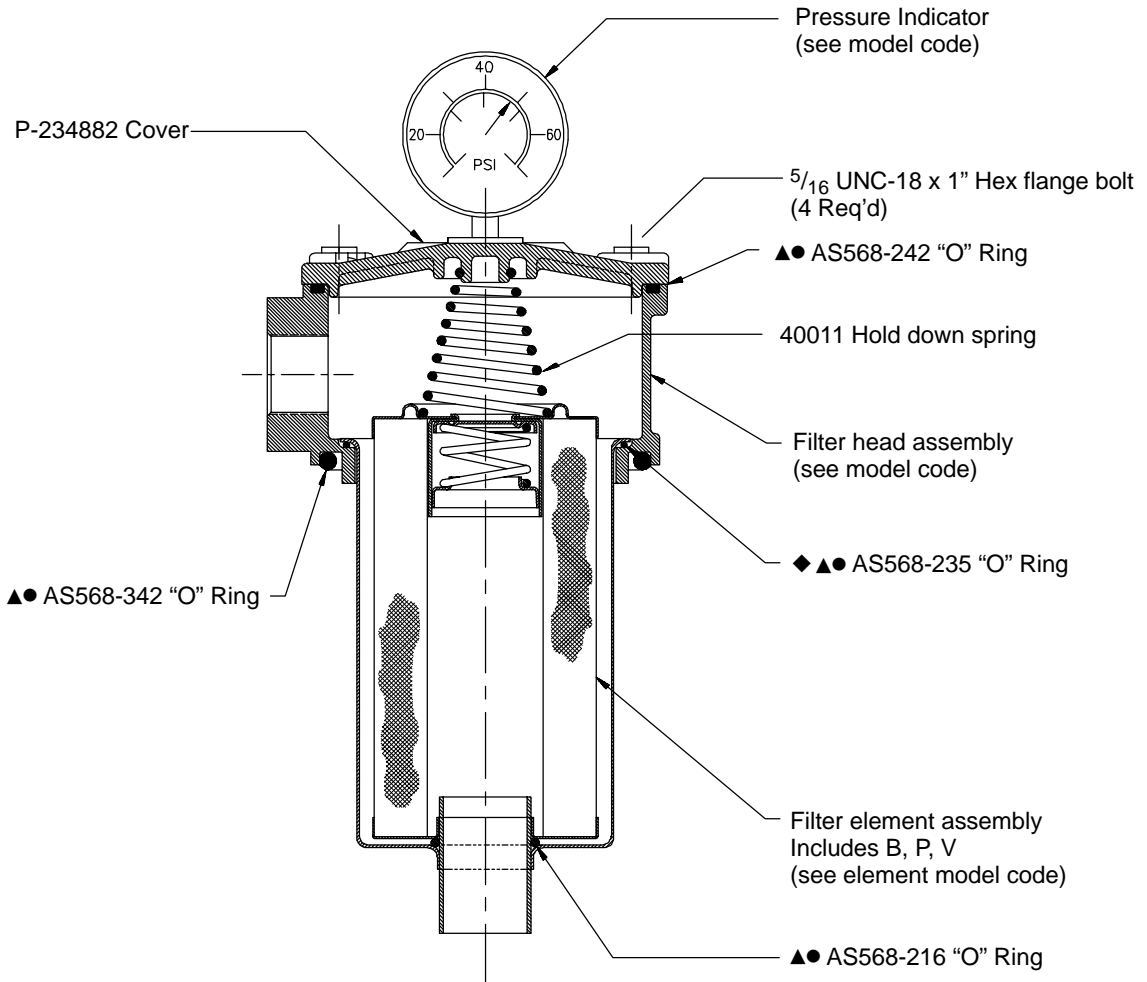

	Bowl length mm (in)	Element code length mm (in)
40017	121,0 (4.76)	133,3 (5.25)

NOTE: Bowl kits contain Buna-N seals, to order Viton seals, replace **B** in partnumber with a **V**.

Example:

From: P-133237-03**B**, for Buna.

To: P-133237-03**V**, for Viton.

- ▲ Included in seal kit P-233054-01 Buna
- Included in seal kit P-233054-03 Viton
- ◆ Included in Bowl kit P-234938

Bowl kits contain (Bowl, "O" Ring)

HT15 Housing Dimensions

mm (inch)

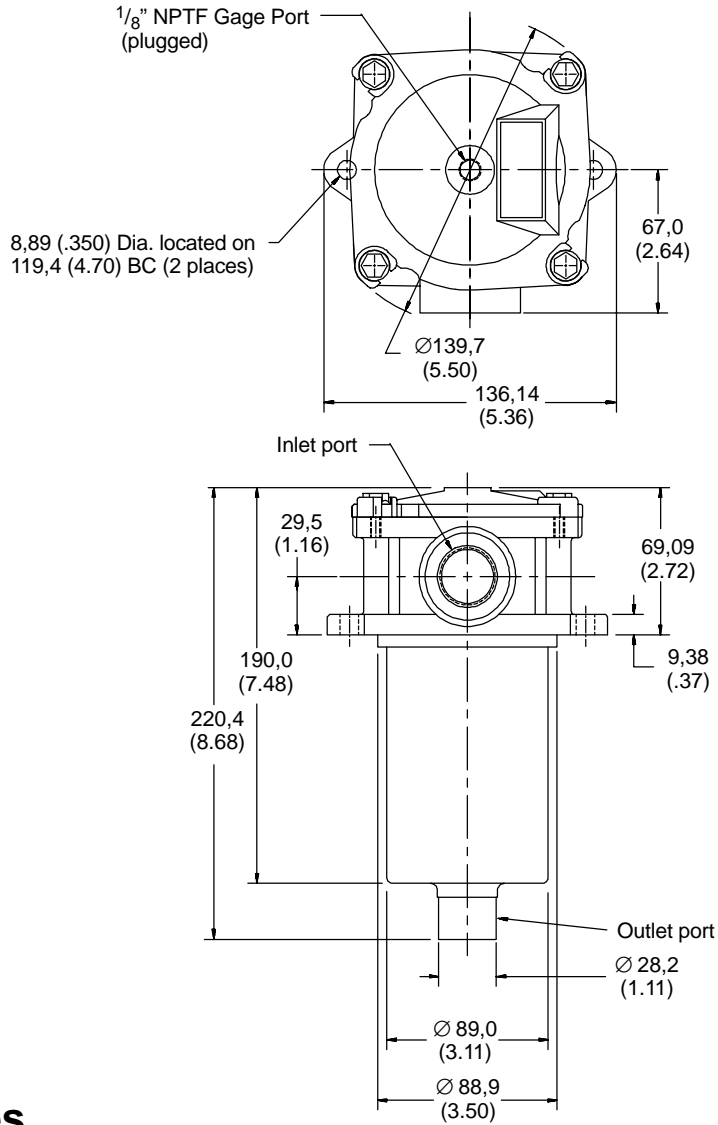

Accessories

Electrical Switch

Switch 1,2 bar (18 psi) Brad Harrison	P-234117-01
Switch 2,4 bar (35 psi) Brad Harrison	P-234118-01
Switch 1,2 bar (18 psi) DIN	P-233051-01
Switch 2,4 bar (35 psi) DIN	P-233573-01

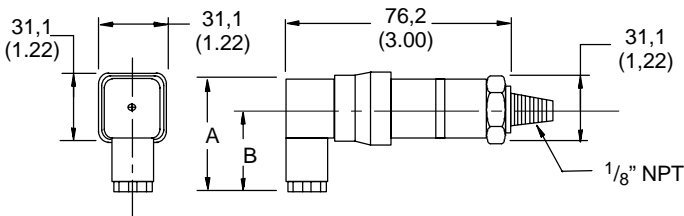

Connector	A	B
DIN 43650	48,2 (1.90)	34,9 (1.37)
Brad Harrison	59,2 (2.33)	45,7 (1.80)

Head Sub-assembly Model Code

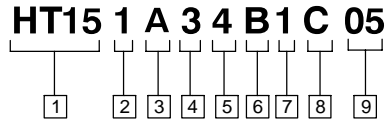

1 Filter series

HT15

2 Element collapse rating

1 – 10 bar (150 PSID)

3 Port option

A – 1.062–12 UN
SAE–12 straight thread

4 Valve bypass setting option

3 – Bypass set at 1.72 ± 0.21 bar
(25 ± 3 PSID) cracking pressure.
(Integral with element)

5 Indicator type

1 – No indicator, pipe plug installed
4 – 0 to 4,14 bar (60 psi pressure gage
6 – Electrical switch 1,24 bar (18 psi)
Brad Harrison
8 – Electrical switch 1,24 bar (18 psi)
DIN 43650

6 Seal material

B – Buna–N
V – Viton–A

**7 Bowl length
mm (in)**

1 – 121,0 (4.76)
S50 - Head subassembly only (no
element, bowl or indicator)

**Element code
length mm (in)**

130,0 (5.1)

8 Element construction

C – C–pak (3,5,10 & 20 grade)

9 Fluid cleanliness ratings

Code	Fluid cleanliness level	Element construction
03	16/14/12 or better	C–pak
05	18/16/14 or better	C–pak
10	20/18/15 or better	C–pak
20	22/19/16 or better	C–pak

Element Model Code

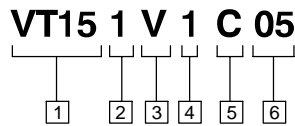

1 Filter element

VT15 – For use with HT15 series filters

2 Element collapse rating

1 – 150 PSID

3 Seal material

V – Viton–A

**4 Bowl length
mm (in)**

1 – 121,0 (4.76)

**Element code
length mm (in)**

130,0 (5.1)

5 Element construction

C – C–pak (3,5,10 & 20 grade)

6 Fluid cleanliness ratings

Code	Target fluid cleanliness level
03	16/14/12 or better
05	18/16/14 or better
10	20/18/15 or better
20	22/19/16 or better

The table above assumes limited ingress and a single pass of pump flow through the element. For more detailed information, please consult Vickers Guide to Systemic Contamination Control **561** or contact your local Vickers Distributor.

Element Dimensions mm (in.)

